

Lithium-Ion Cell - LI18650JD-25P Power Type



- High Discharge Current
- Long Cycle Life
- Low Self-Discharge
- Fast Charging Capability



SPECIFICATIONS	
Jauch Part Number	251584
Nominal Voltage	3.6 V
Charging Voltage	4.2 V
Rated Capacity	2500 mAh
Standard Discharge Current	20 A (@ ambient temp.)
Max. Discharge Current (cont.)	30 A (80°C temperature cut)
Standard Charge Current	2.5 A
Max. Charge Current (cont.)	6.0 A
Discharge Ending Voltage	2.5 V
Standard Charge cut-off current	50 mA
Internal Resistance	≤16 mΩ (ACIR)
Weight	Approx. 47 g
Operating Temperature Charge	0°C to +60°C
Operating Temp. Discharge	-20°C to +80°C
UL1642	MH62838

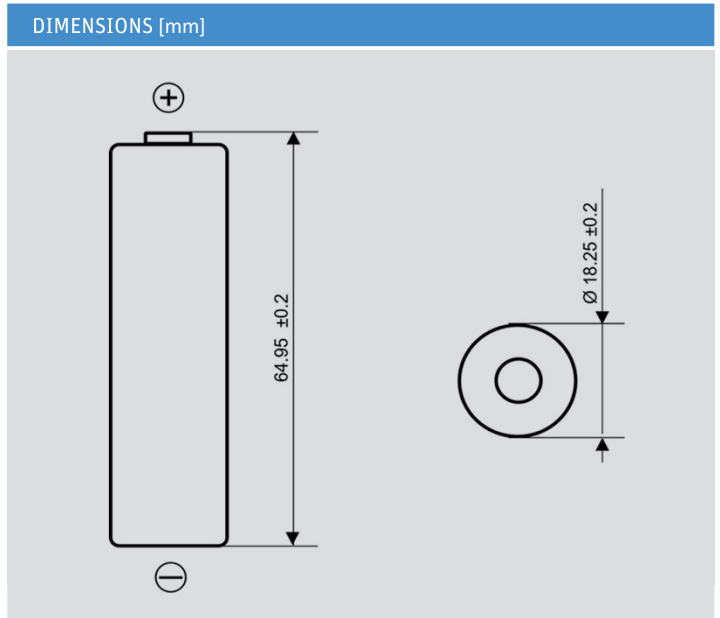

For full specifications, please contact batterytechnology@jauch.com.

