



Lithium-Ion Cell - LI18650JD-35E Energy Type

- High Energy Density
- Long Cycle Life
- Low Self-Discharge
- Fast Charging Capability



SPECIFICATIONS	
Jauch Part Number	252065
Nominal Voltage	3.6 V
Charging Voltage	4.2 V
Rated Capacity	3500 mAh
Standard Discharge Current	1 C
Max. Discharge Current (cont.)	10A
Standard Charge Current	0.5 C
Max. Charge Current (cont.)	1 C
Discharge Ending Voltage	2.5 V
Standard Charge cut-off current	50mA
Internal Resistance	≤30 mΩ (ACIR)
Weight	Approx. 50g
Operating Temperature Charge	0°C to +50°C
Operating Temp. Discharge	-20°C to +60°C
UL1642	MH62838

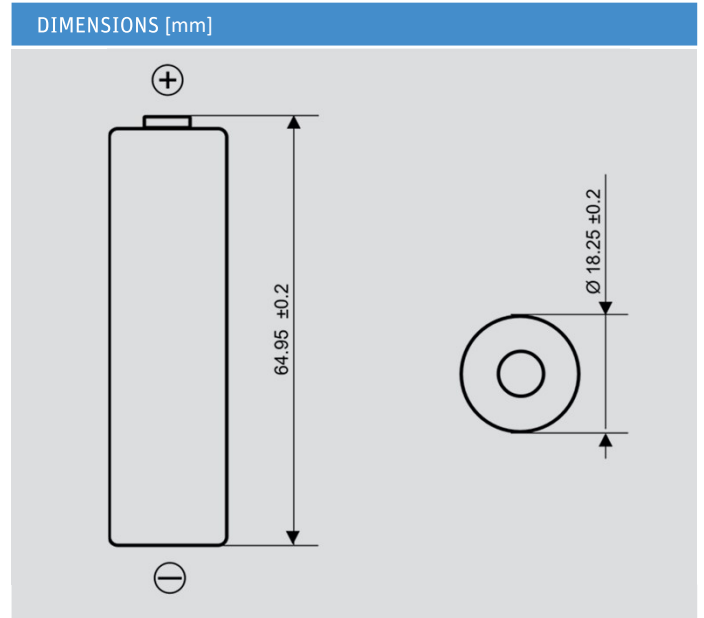

For full specifications, please contact batterytechnology@jauch.com.

